

# Thermostrip™ DC - Temperature Tape for Drying and Curing

Every link in the cold chain is crucial to your product's safety and quality. Temperature Thermostrip™ DC is a highly accurate heat indicator designed for use within a drying, curing, laminating or bonding process.

- The individual strip has 5 temperature settings that when exposed to heat will permanently change color from silver to black indicating attained temperature
- Attach to the product in process
- For use in dry applications
- Permanent visible record
- Eight (8) temperature sets

### Perfect for:

- Heat Indicators within curing systems found on many web and laminating presses
- Assisting with determining how UV inks react at various temperatures
- Temperature testing when using a fusing machine, confirming temperature at bonding site
- Insuring that garments finished or pressed in a temperature tunnel - do not overheat
- For use during screen printing, textile processing, plastic laminating and curing printing inks to provide evidence of attained temperature

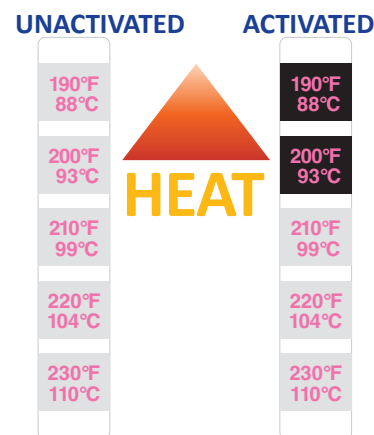
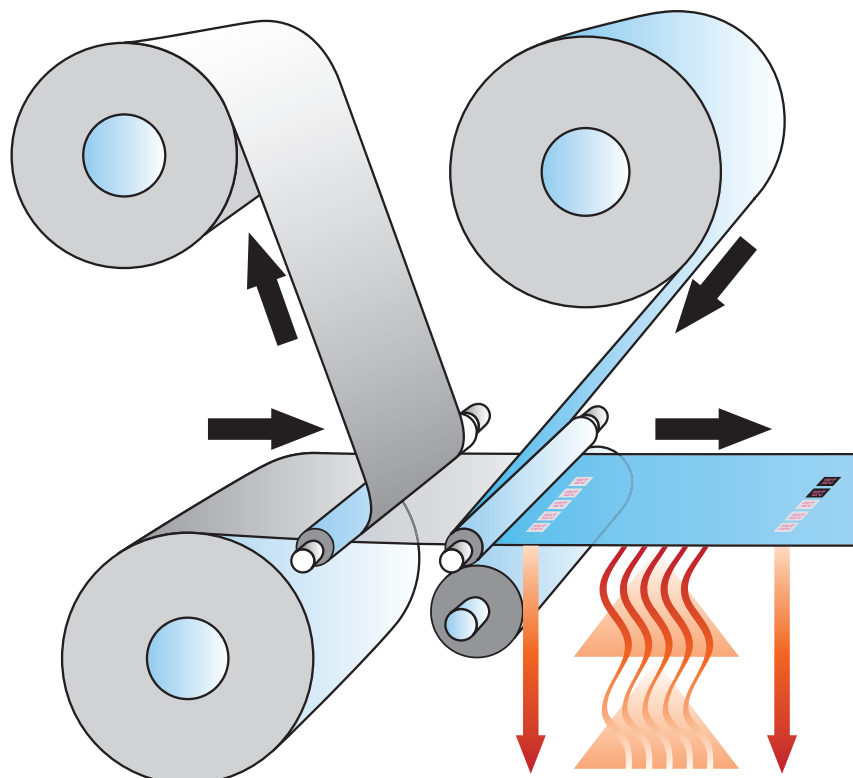

CODE #	SET	TEMPERATURE RANGE °C					SPECIFICATIONS
P9016-16	1	37°	40°	44°	49°	54°	• 7°C to 260°C
P9017-16	2	60°	65°	71°	77°	82°	• 10 mm x 56 mm
P9018-16	3	88°	93°	99°	104°	110°	• Self-Adhesive label
P9019-16	4	116°	121°	127°	132°	138°	• Accuracy
P9020-16	5	143°	149°	154°	160°	166°	Set 1 & 2 Tolerance: ± 1°C
P9021-16	6	171°	177°	182°	188°	193°	Set 3 & 4 Tolerance: ± 1.5°C
P9022-16	7	199°	204°	210°	216°	224°	Set 5 – 8 Tolerance: ± 4°C
P9023-16	8	232°	241°	249°	254°	260°	• 16 labels per set